

[Body]

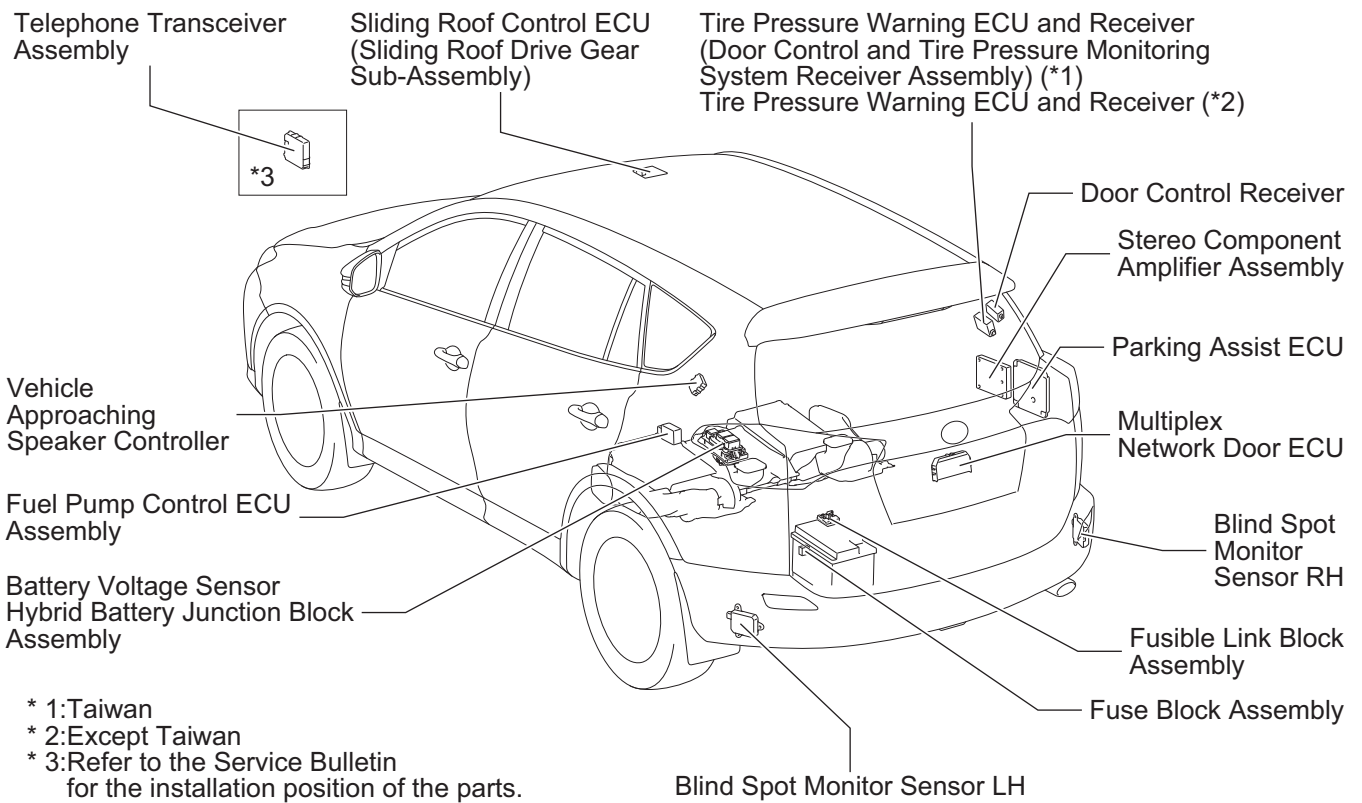

[Engine Compartment]

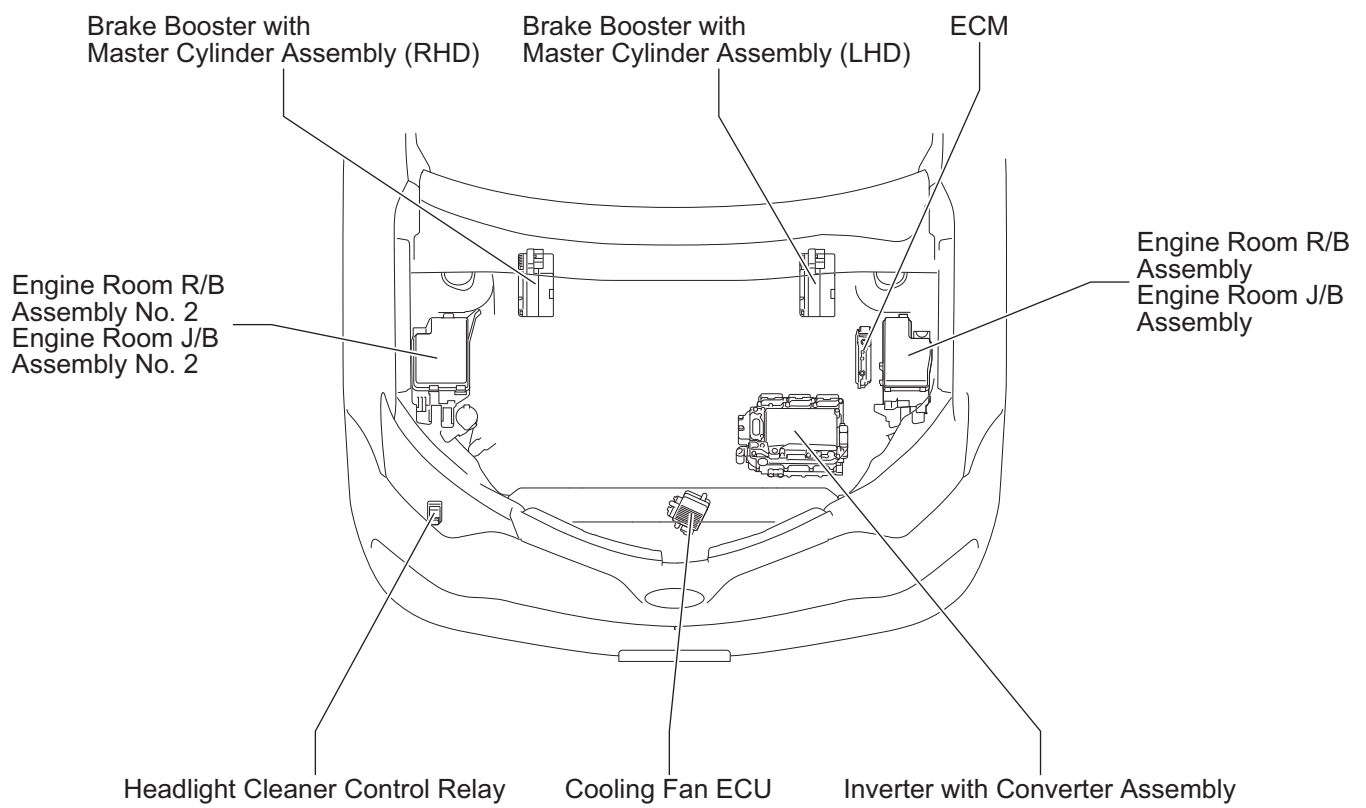

① : Engine Room R/B Assembly

○ : Engine Room J/B Assembly

Front Fender Apron LH

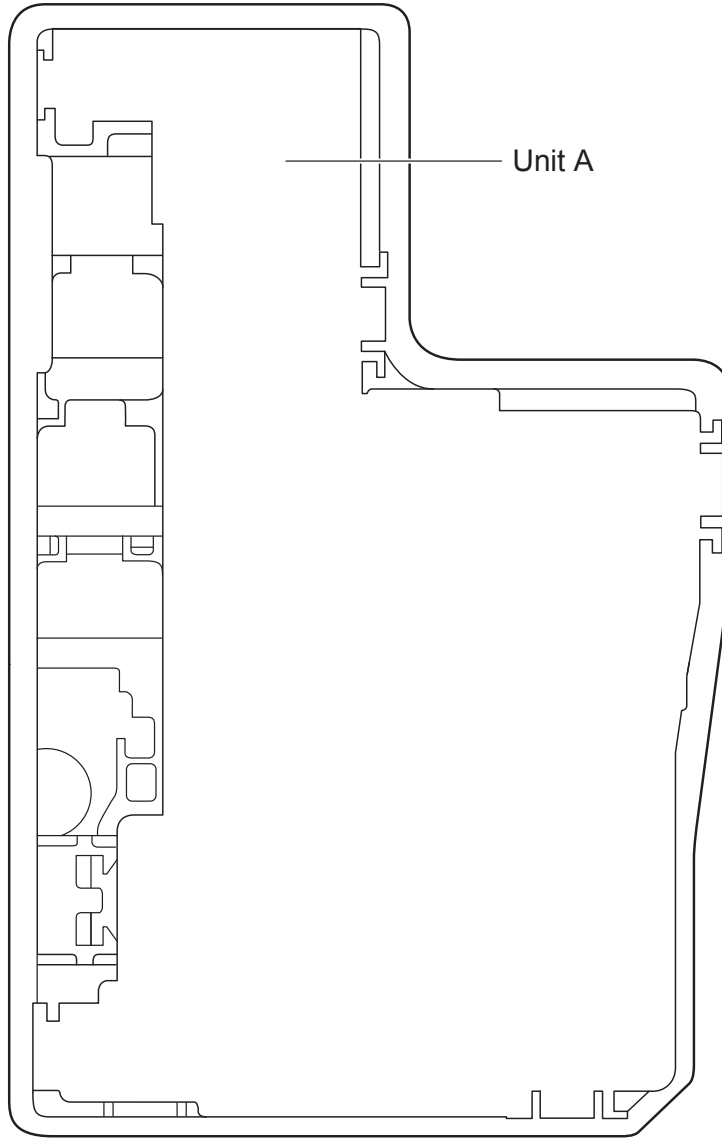

Unit A

Top View

- * 1:120A DC/DC
- * 2:80A EPS
- * 3:50A ABS MTR NO.1
- * 4:50A H-LP-MAIN
- * 5:50A ABS MTR NO.2
- * 6:From Aug. 2016 Production

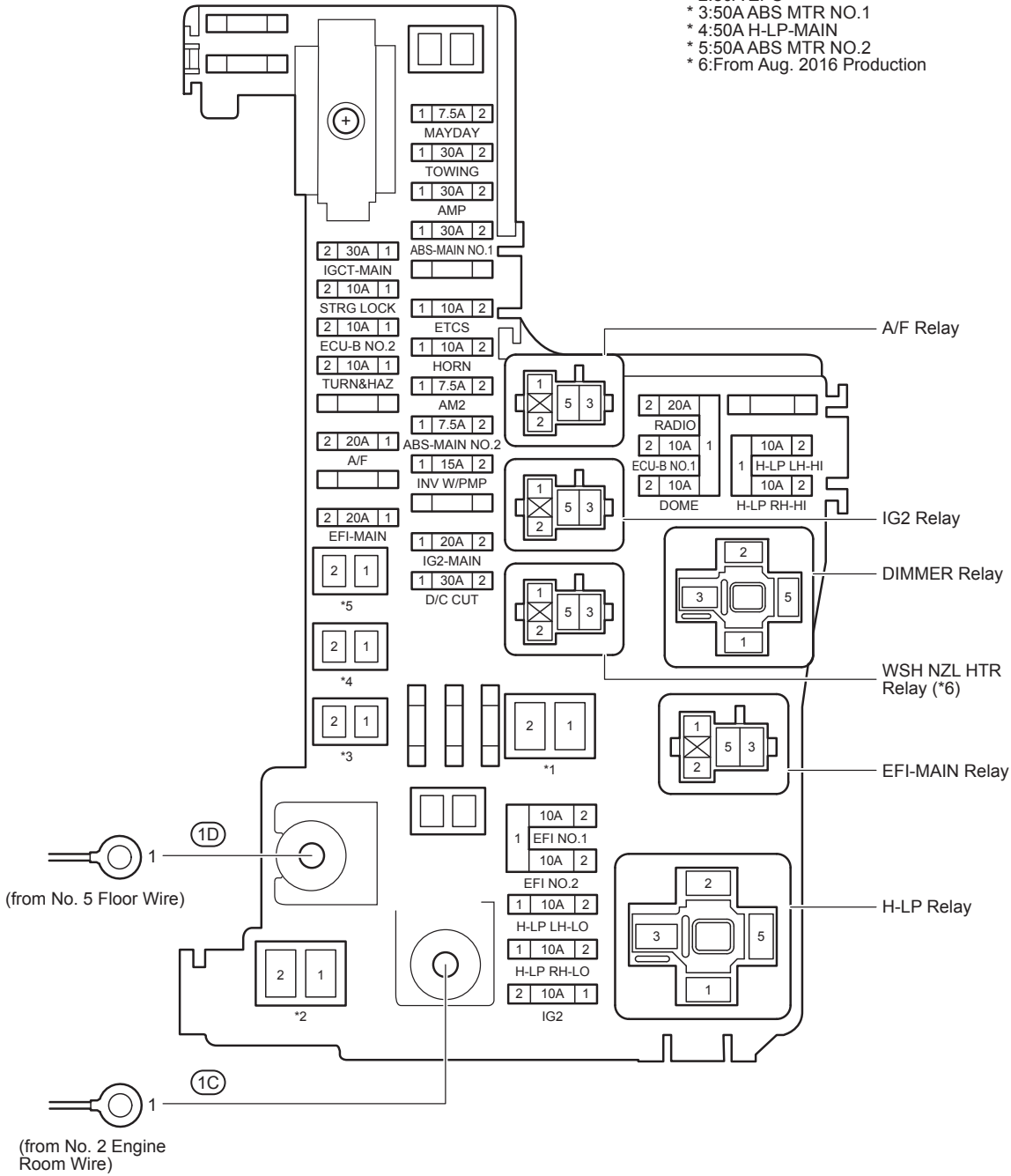

① : Engine Room R/B Assembly

○ : Engine Room J/B Assembly

Front Fender Apron LH

Unit A

Back View

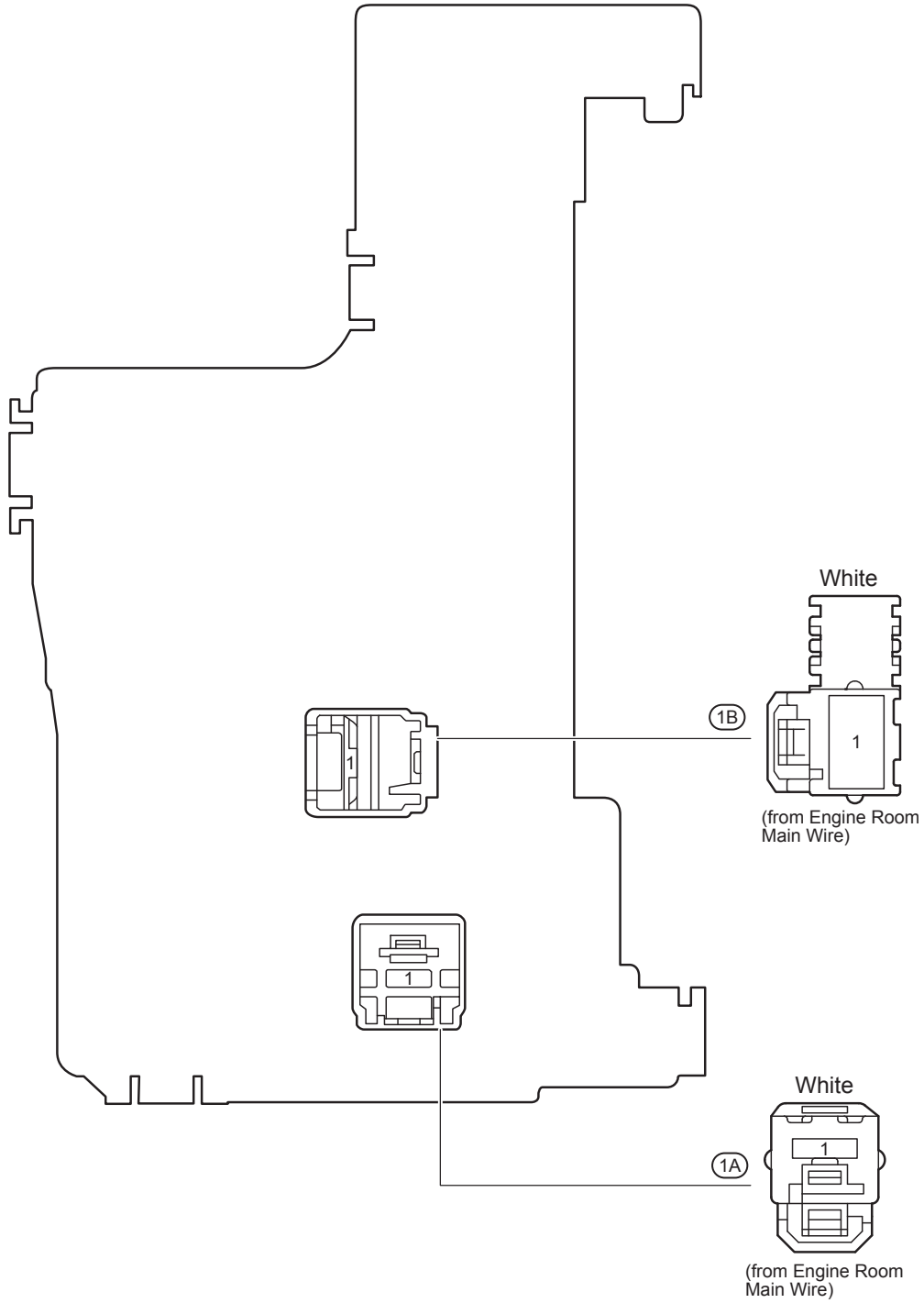

(Cont'd)

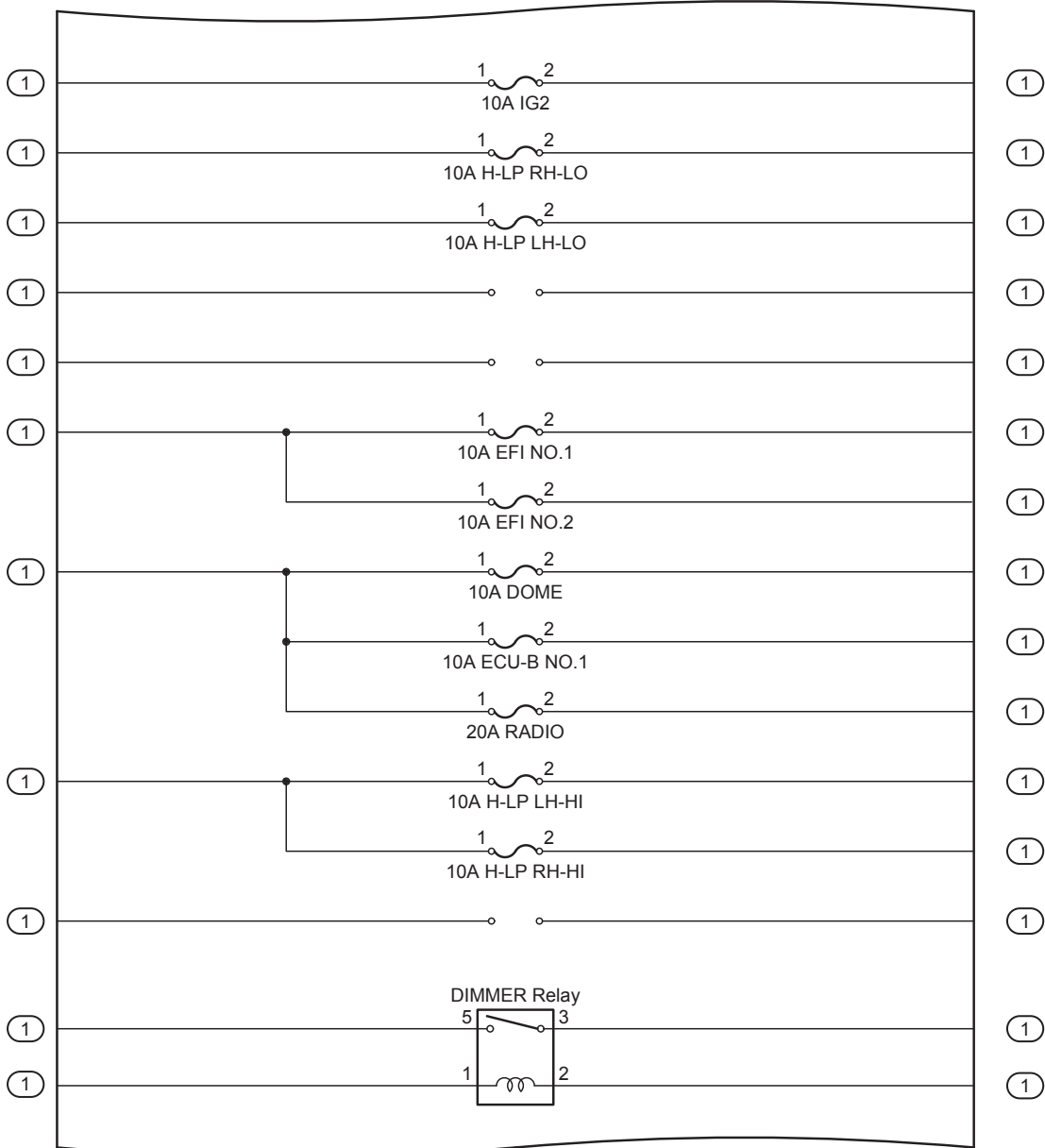

(Cont. Next Page)

[Engine Room R/B Assembly and Engine Room J/B Assembly Inner Circuit]

(Cont'd)

* 1:From Aug. 2016 Production

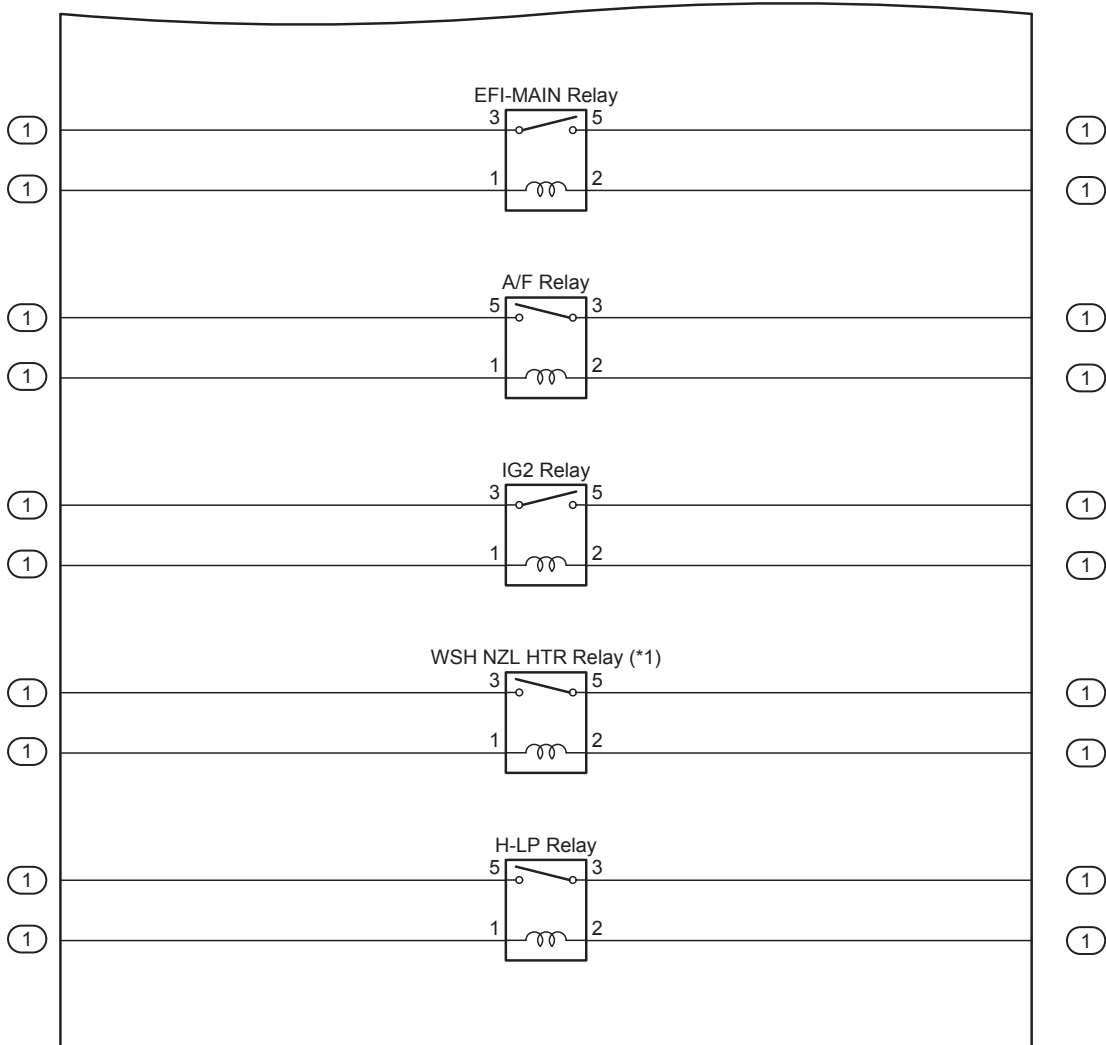

② : Engine Room R/B Assembly No. 2

○ : Engine Room J/B Assembly No. 2

Front Fender Apron RH

- * 1:50A HTR
- * 2:30A H-LP CLN
- * 3:50A PTC HTR NO.1
- * 4:50A HWD NO.2
- * 5:50A HWD NO.1
- * 6:30A PTC HTR NO.3
- * 7:30A PTC HTR NO.2
- * 8:80A FAN
- * 9:30A DEF
- * 10:w/ Windshield Deicer
- * 11:w/o Windshield Deicer
- * 12:DEICER Relay (*10)
- WSH NZL HTR Relay (*11 *13)
- * 13:Before Aug. 2016 Production

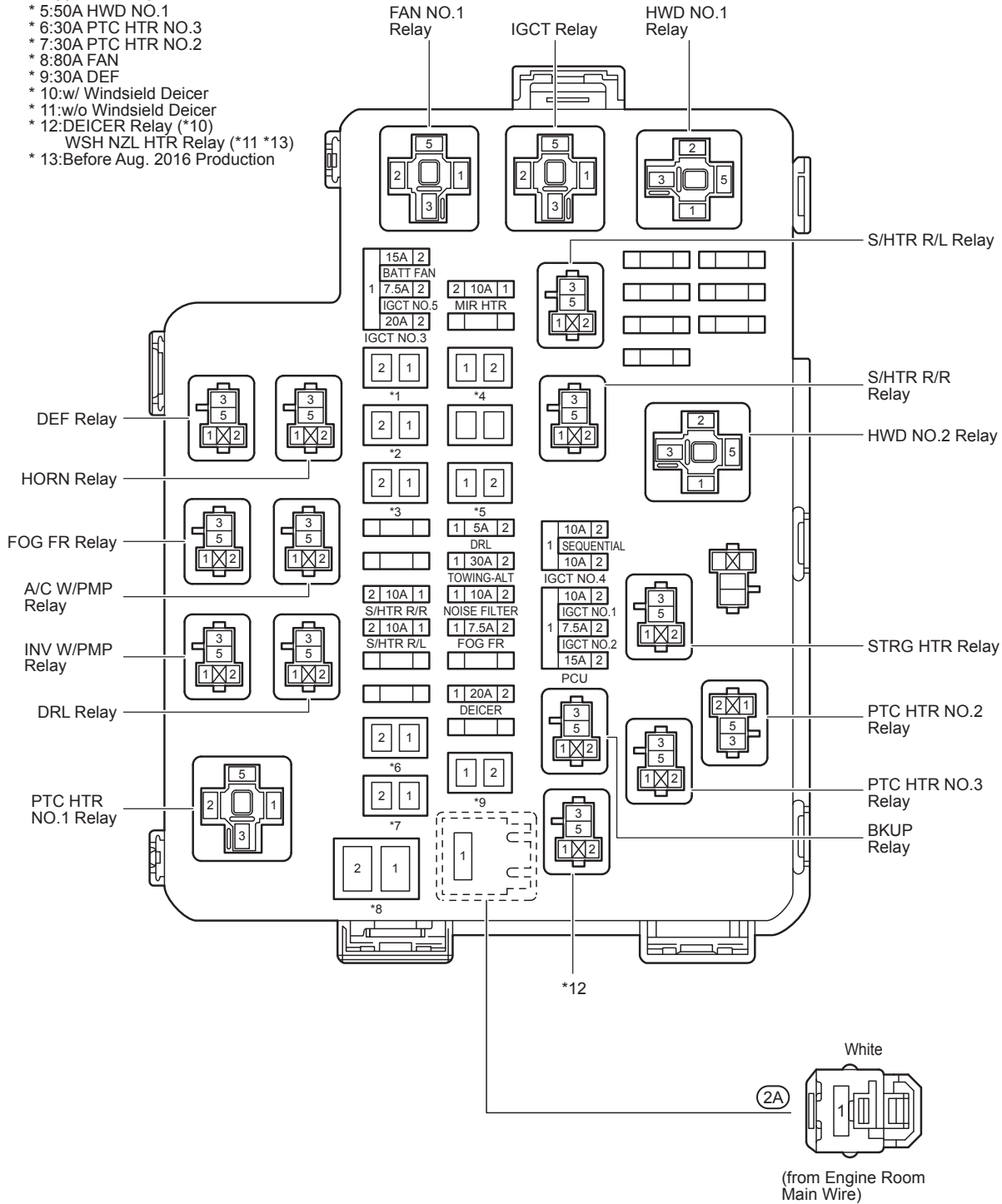

[Engine Room R/B Assembly No. 2 and Engine Room J/B Assembly No. 2 Inner Circuit]

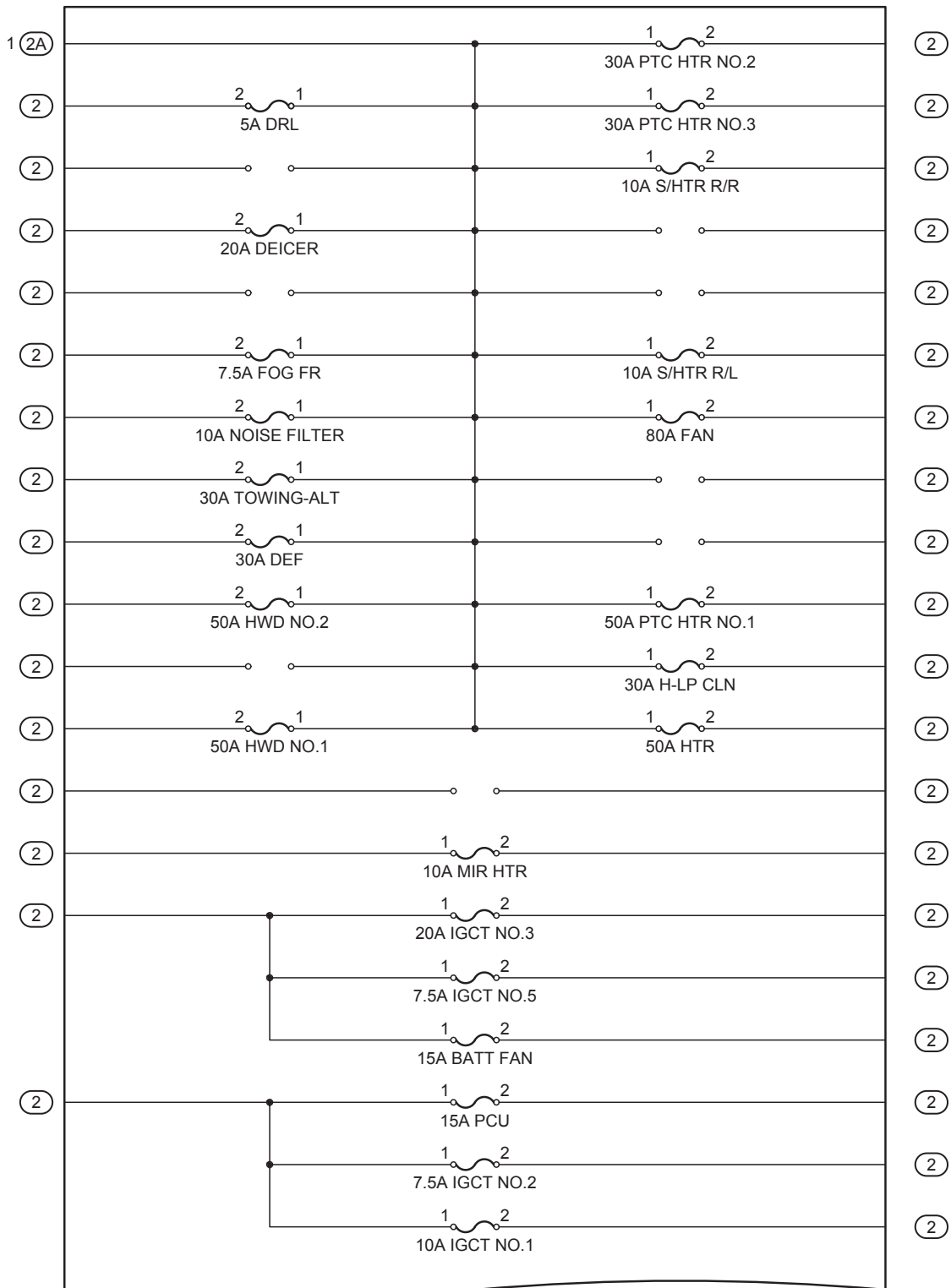

(Cont. Next Page)

(Cont'd)

* 10:w/ Windsield Deicer
* 11:w/o Windsield Deicer
* 13:Before Aug. 2016 Production

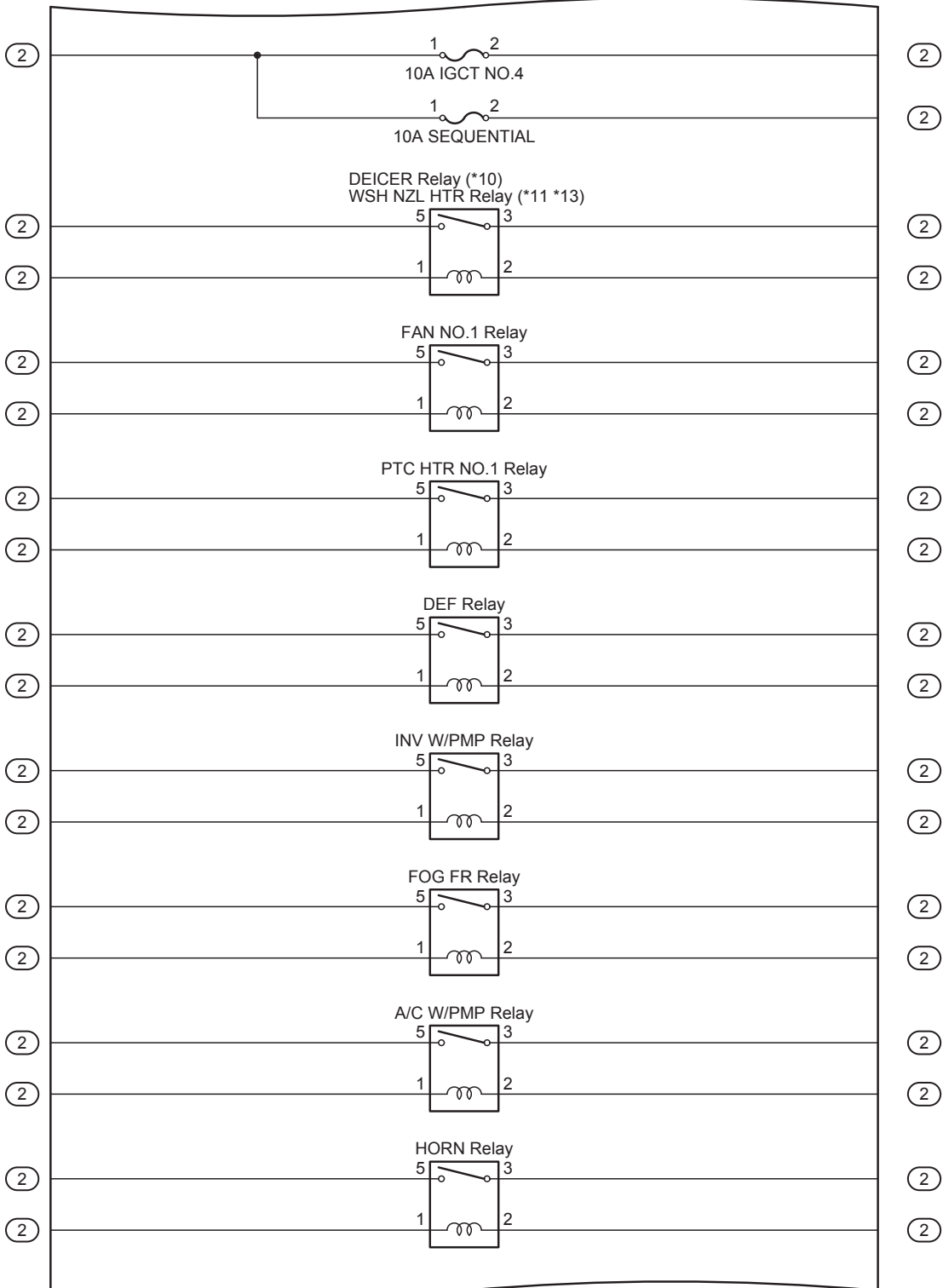

(Cont. Next Page)

[Engine Room R/B Assembly No. 2 and Engine Room J/B Assembly No. 2 Inner Circuit]

(Cont'd)

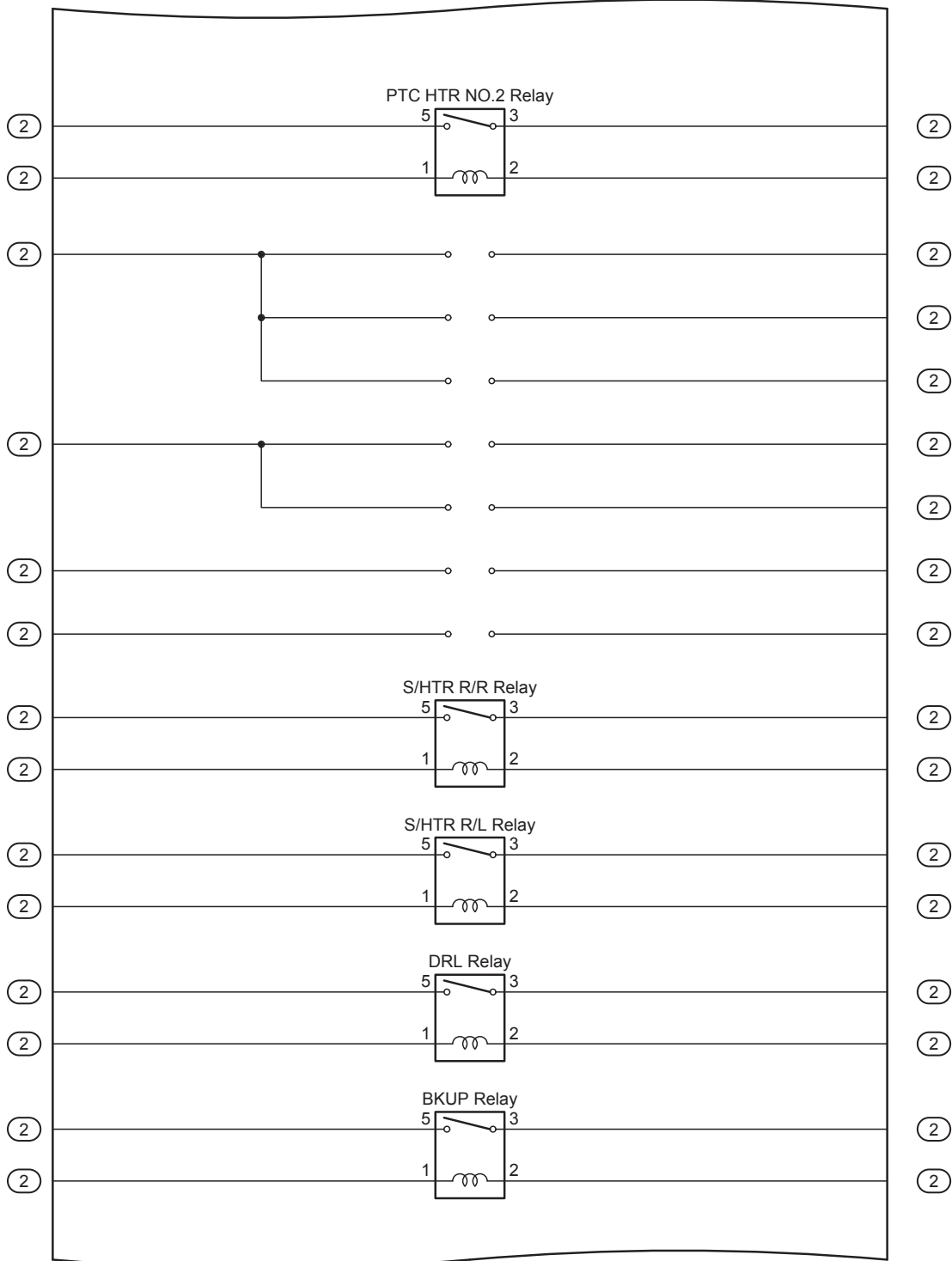

(Cont. Next Page)

(Cont'd)

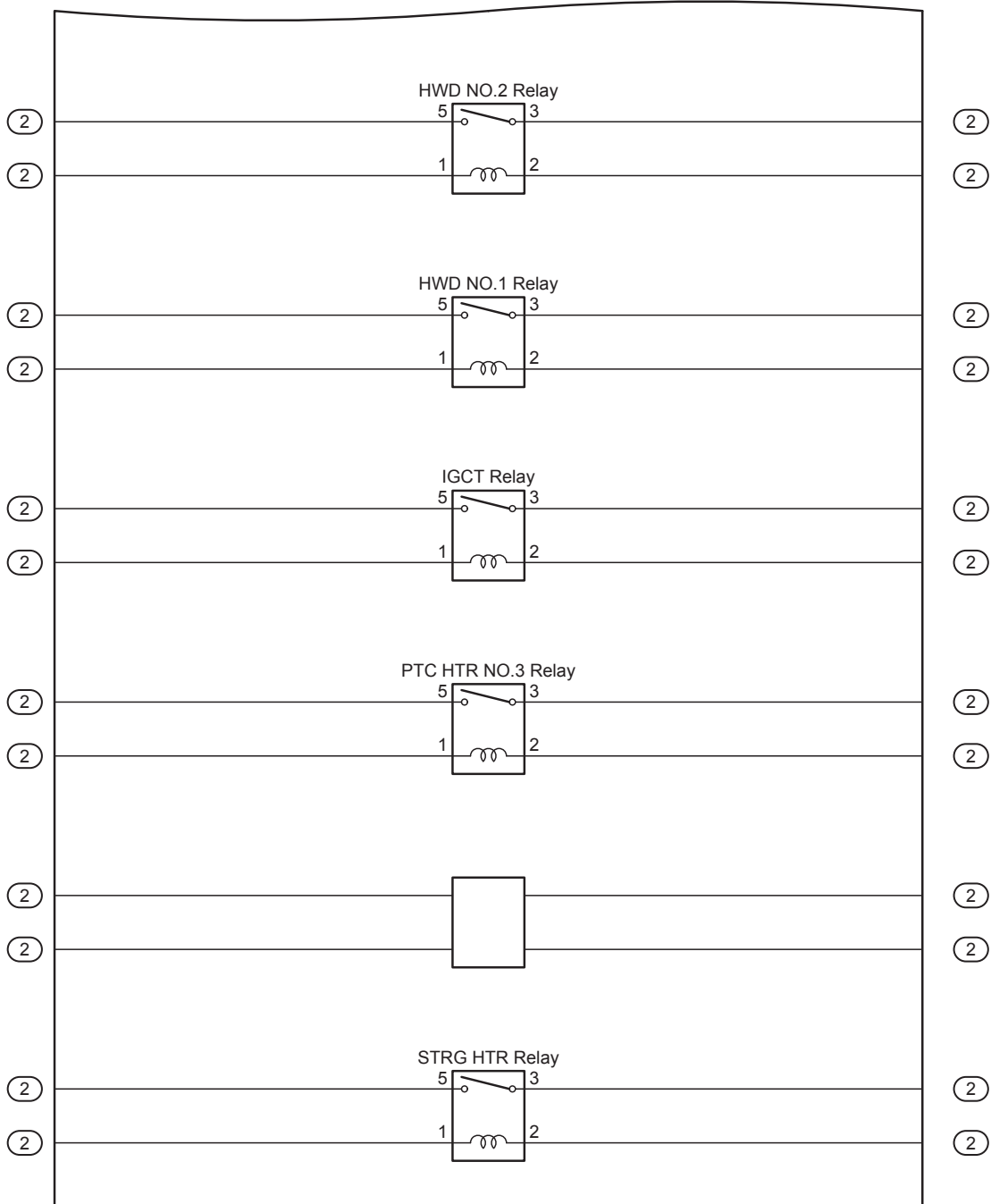

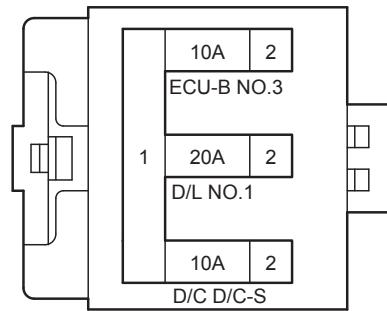

[Fuse Block Assembly Inner Circuit]

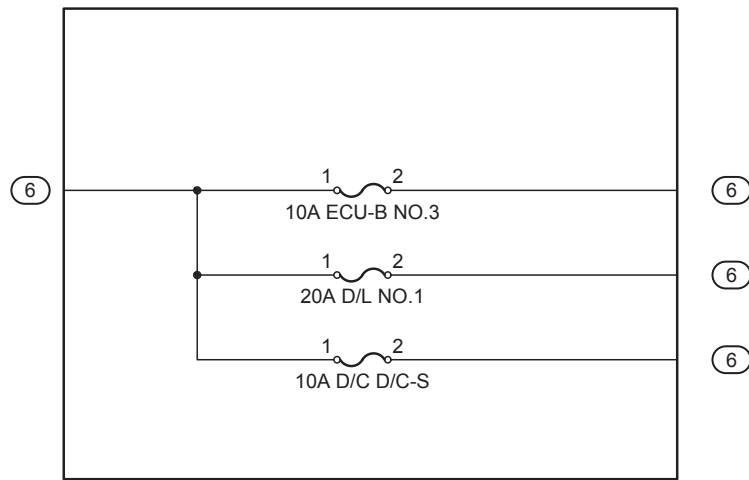

Fusible Link Block Assembly Quarter Panel LH

Side View

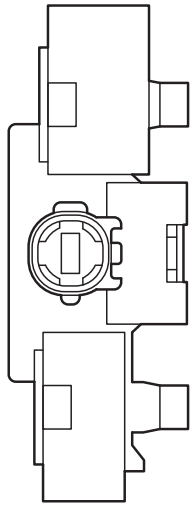

Top View

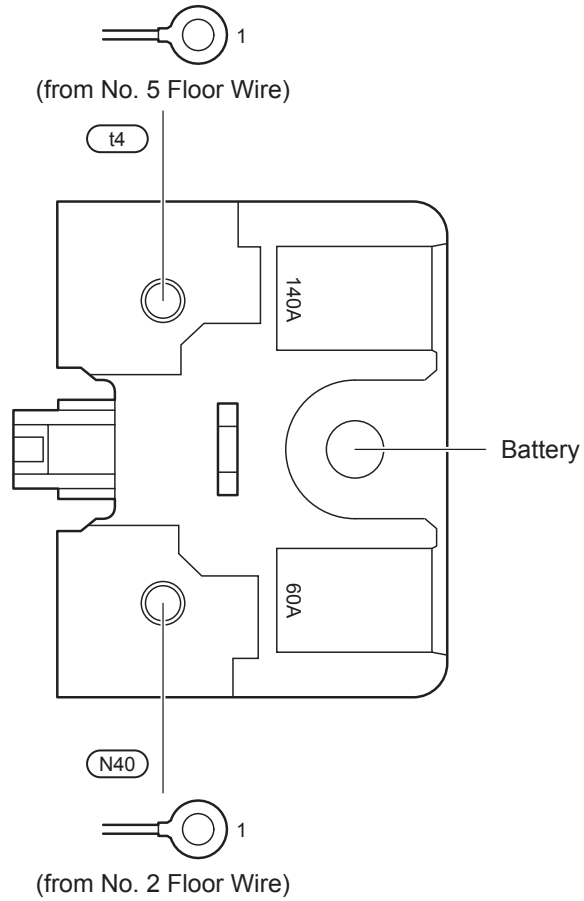

[Fusible Link Block Assembly Inner Circuit]

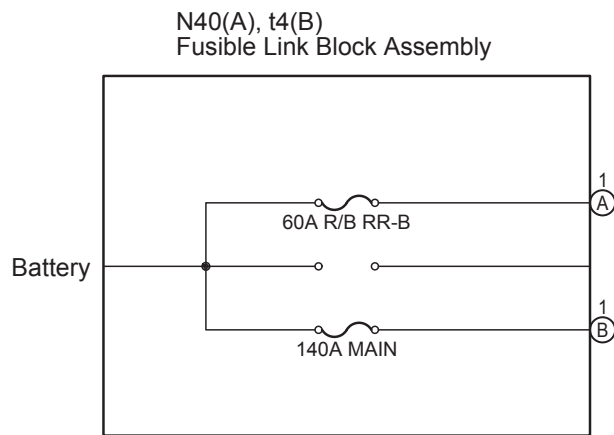

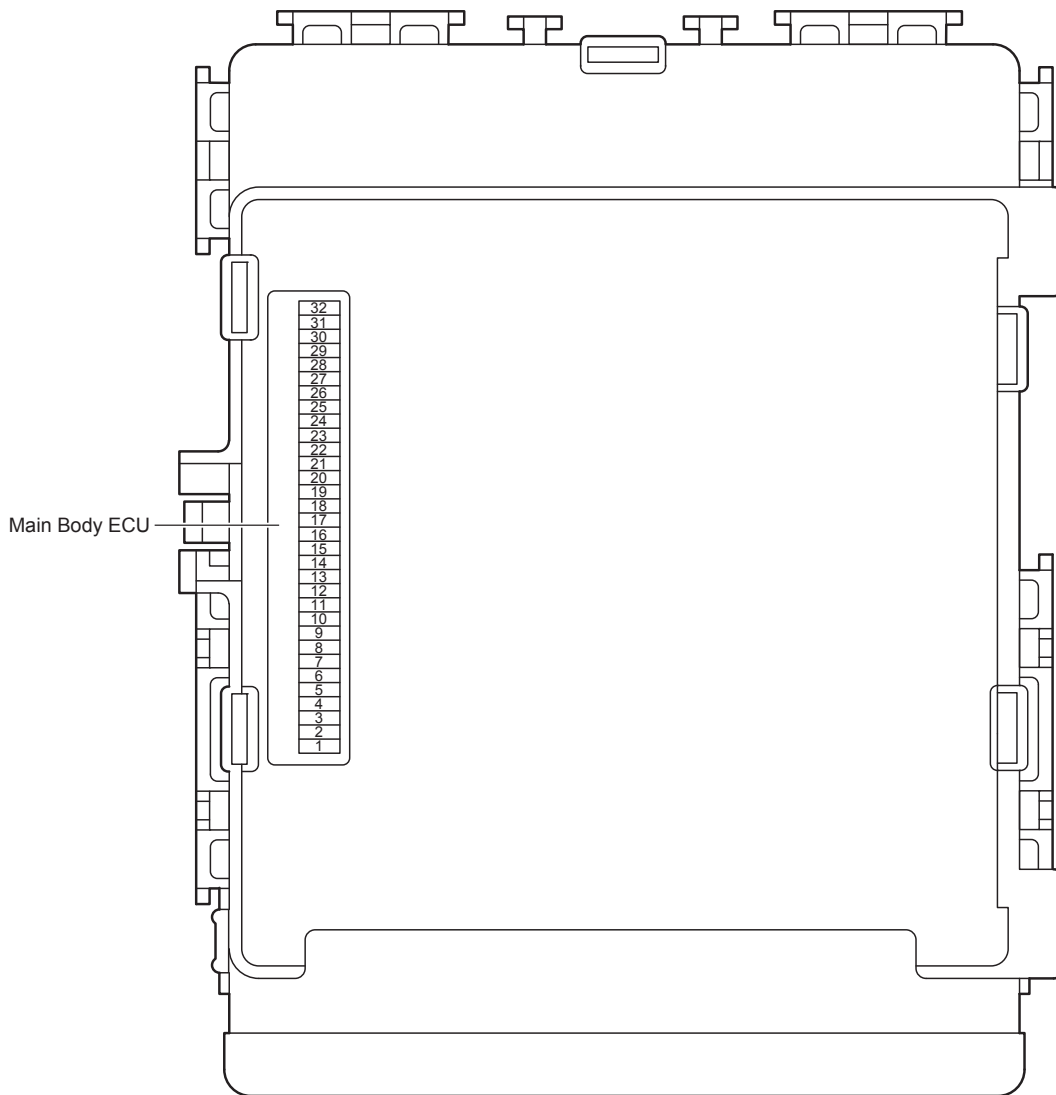

[Instrument Panel J/B Assembly Inner Circuit]

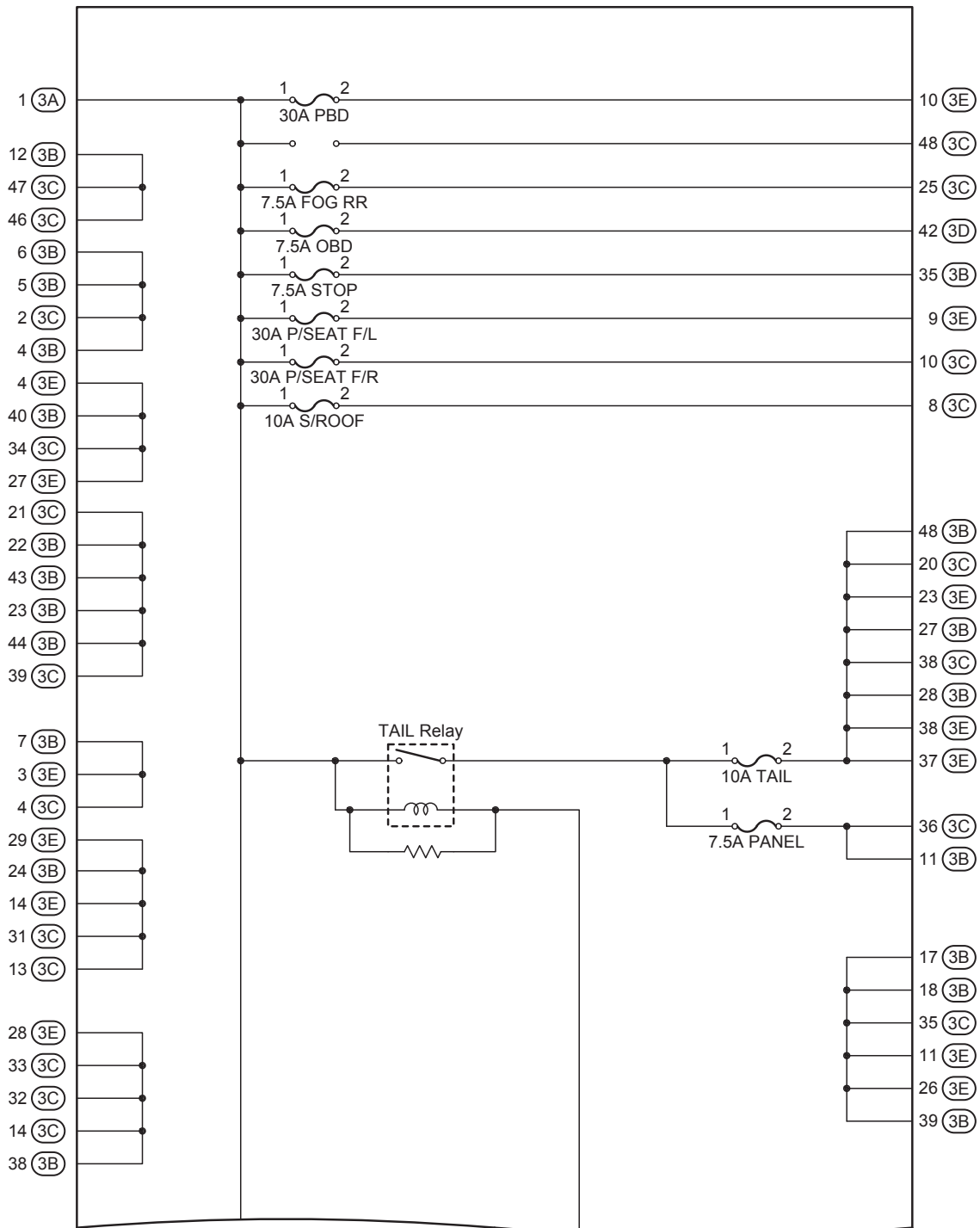

(Cont. Next Page)

* 1:Korea
 * 2:Except Korea

(Cont'd)

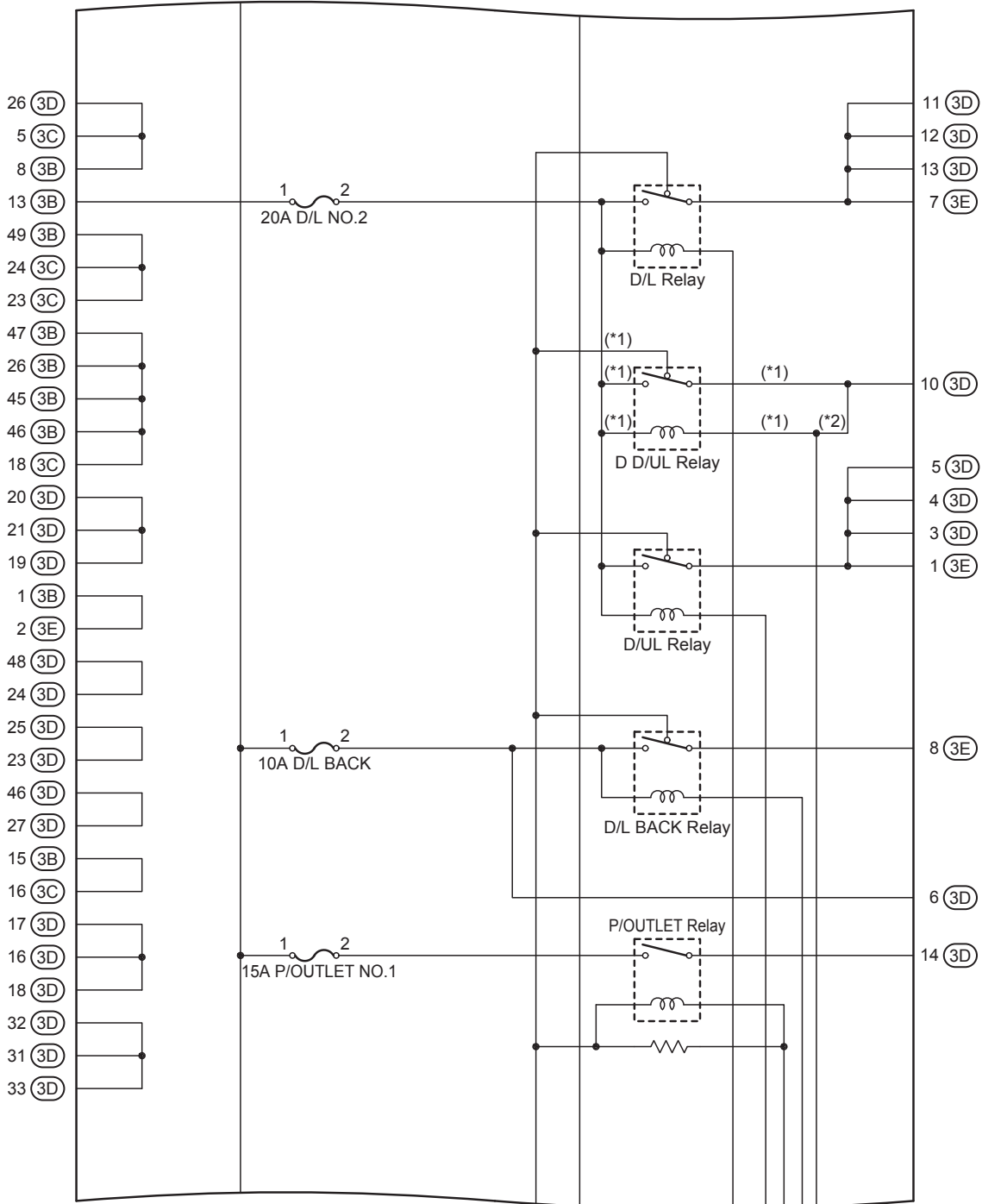

(Cont. Next Page)

[Instrument Panel J/B Assembly Inner Circuit]

(Cont'd)

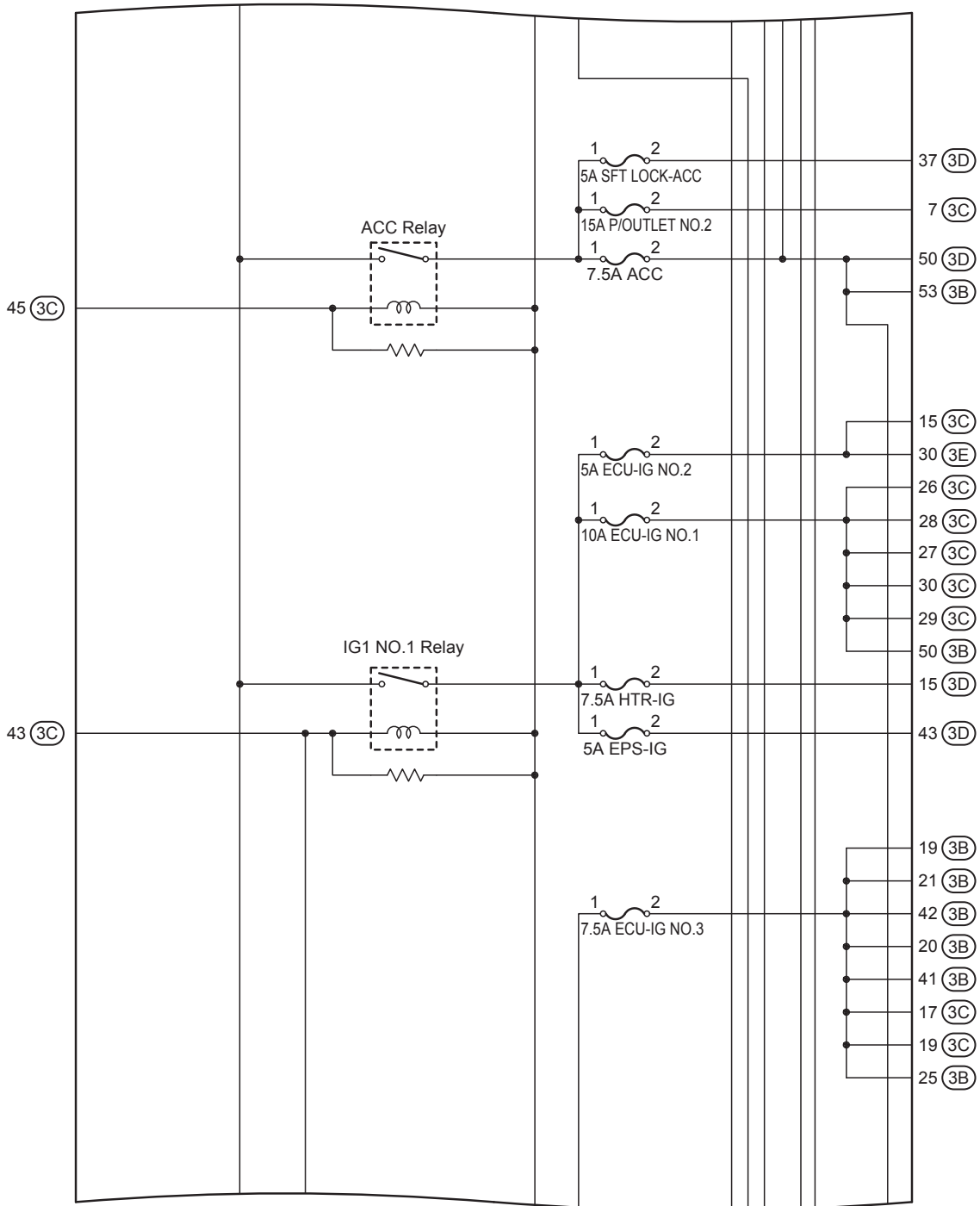

(Cont. Next Page)

(Cont'd)

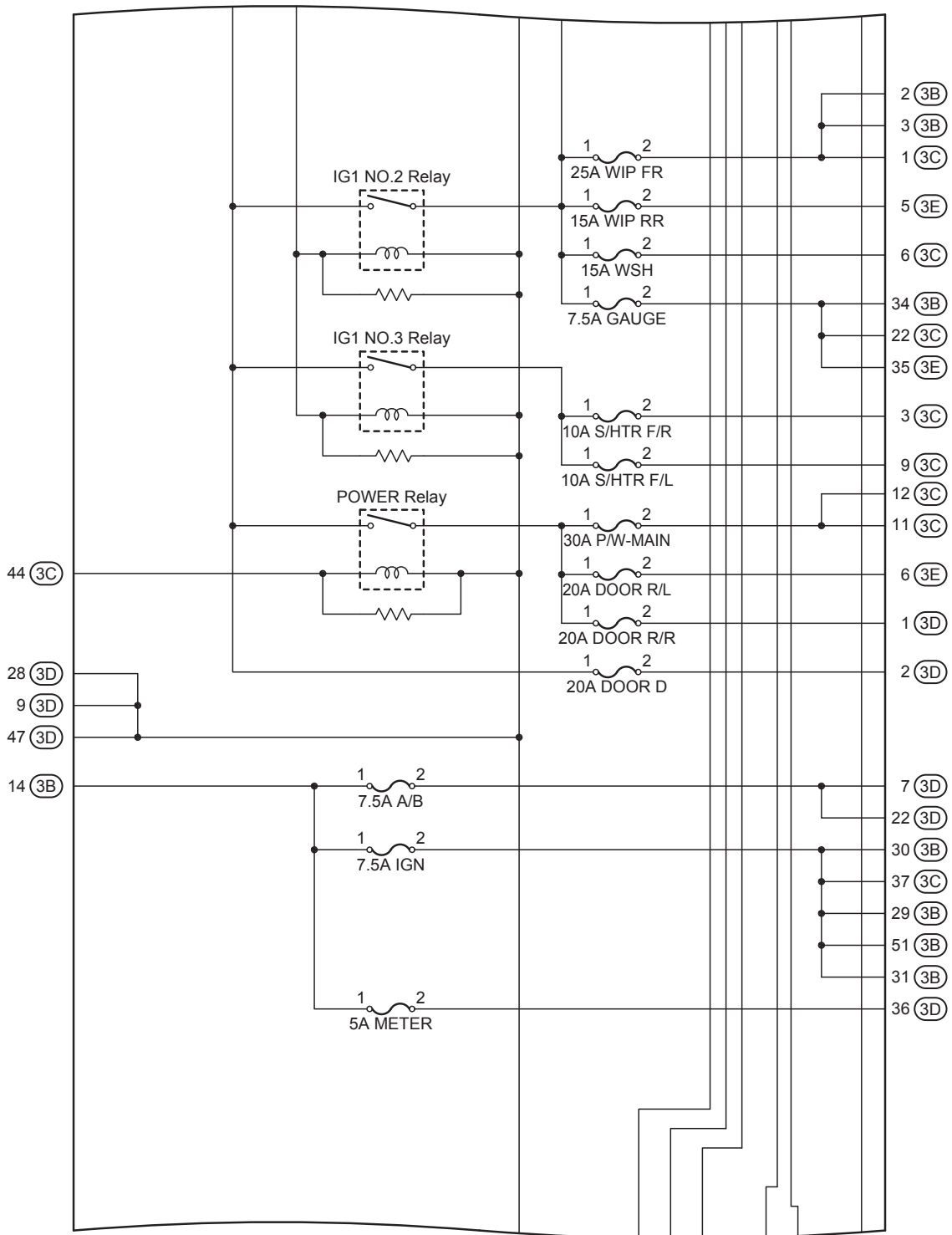

(Cont. Next Page)

[Instrument Panel J/B Assembly Inner Circuit]

(Cont'd)

* 1:Korea
* 2:Except Korea

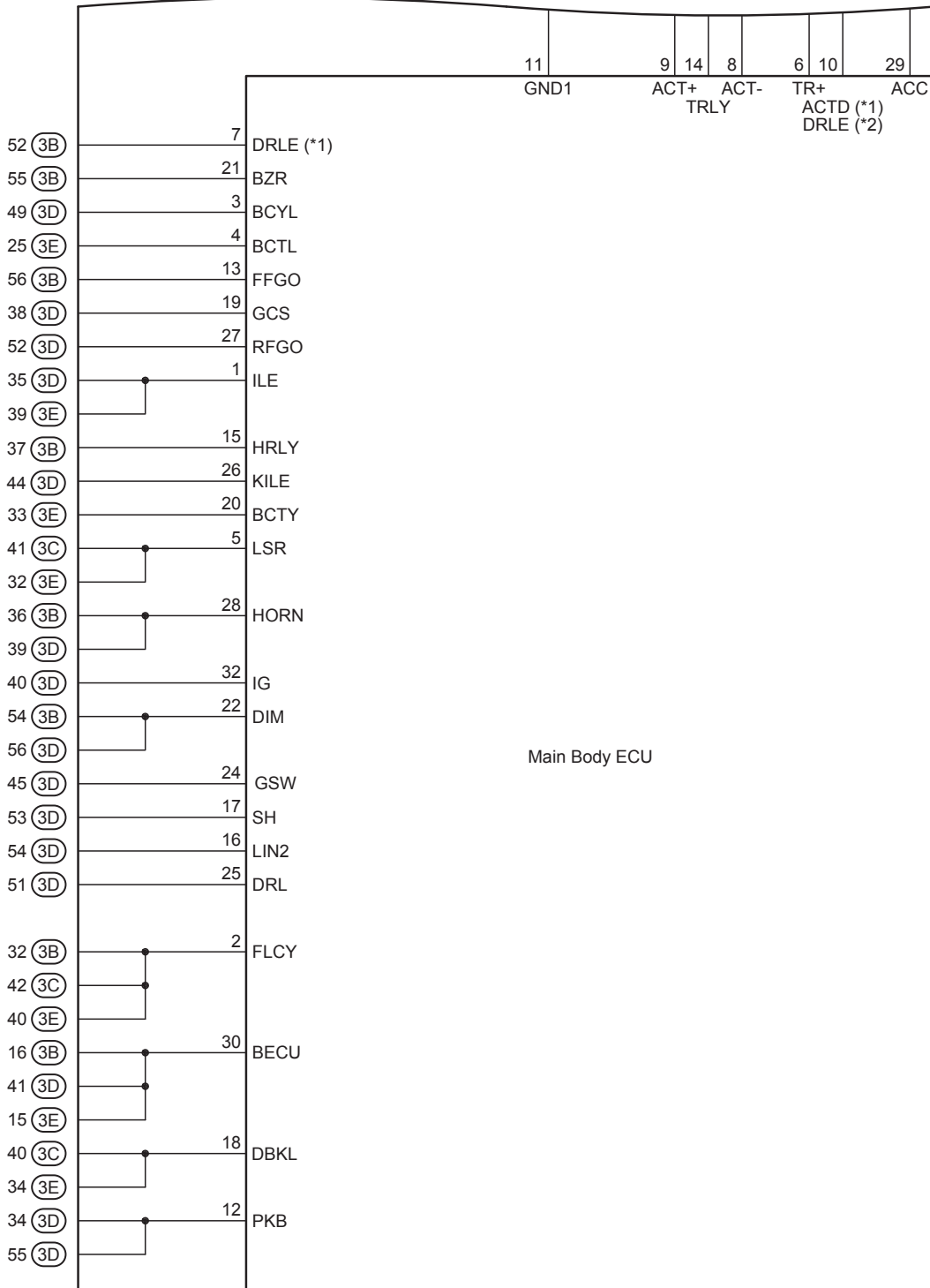

[Instrument Panel] (LHD)

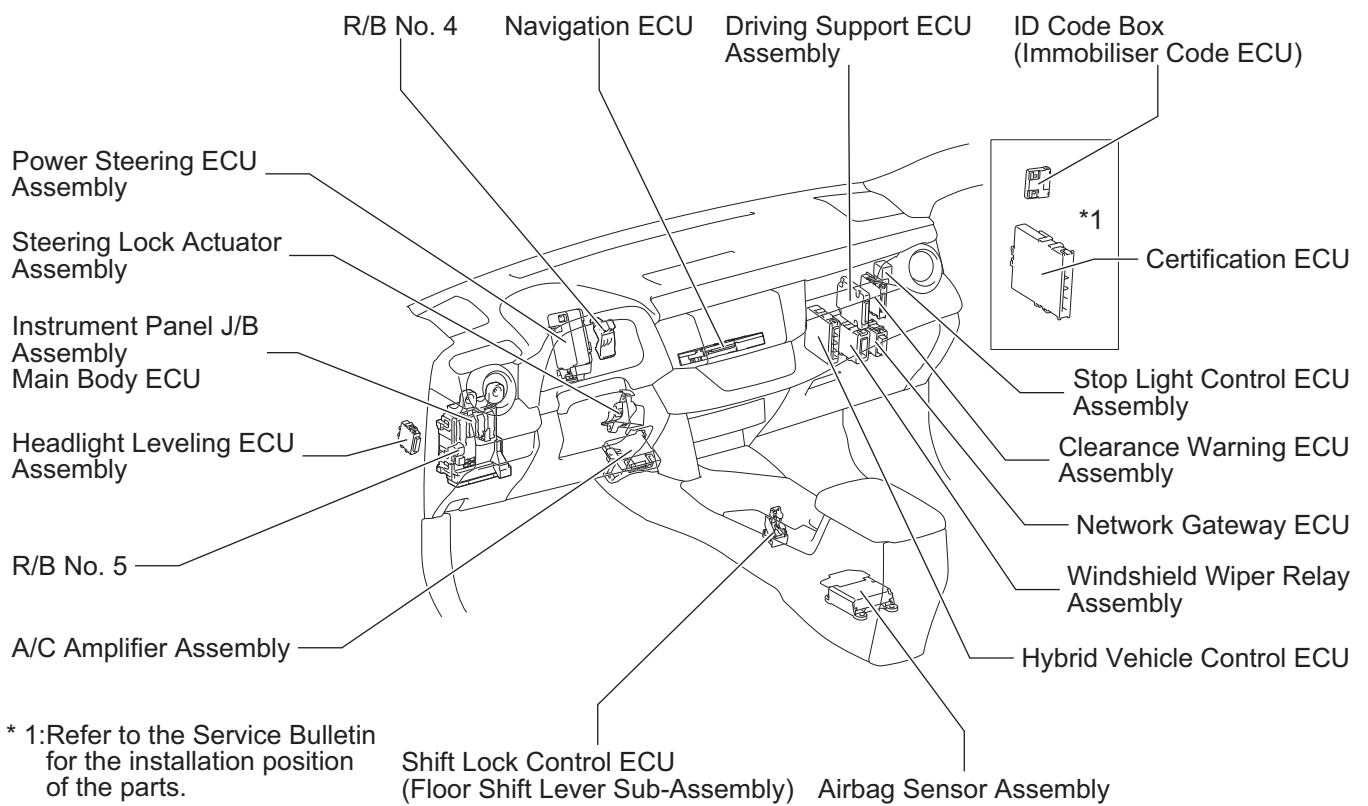

(RHD)

* 1: Refer to the Service Bulletin for the installation position of the parts.

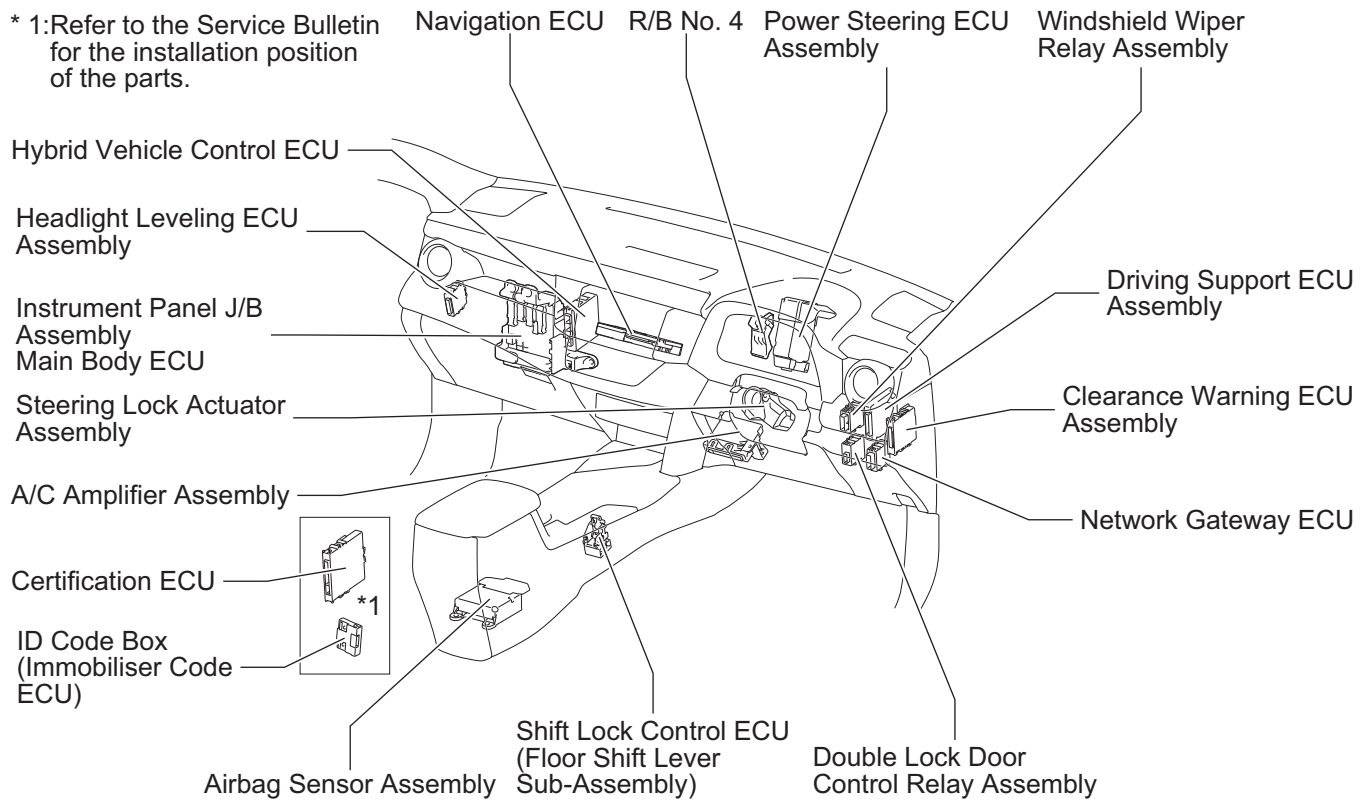

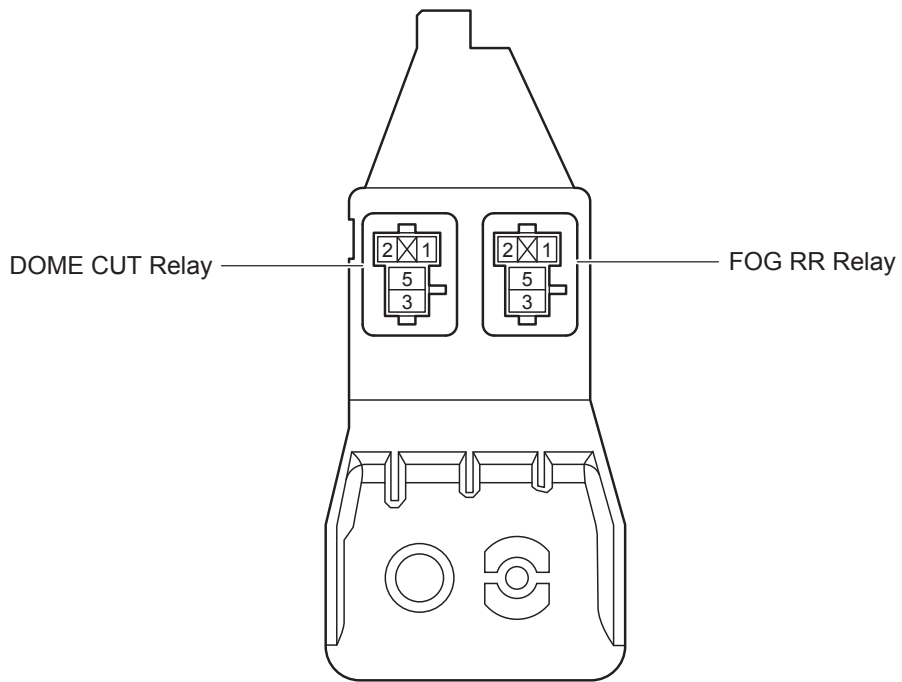

[R/B No. 4 Inner Circuit]

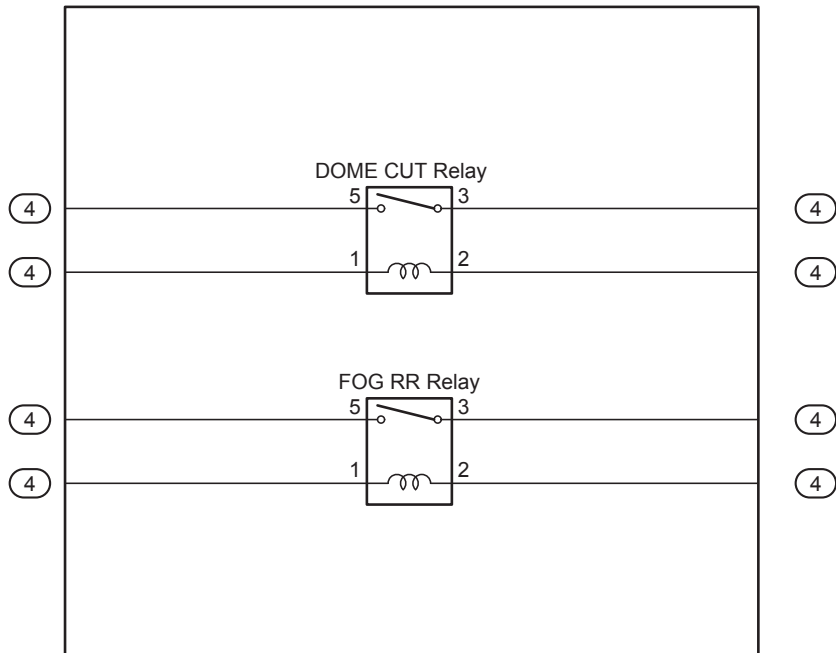

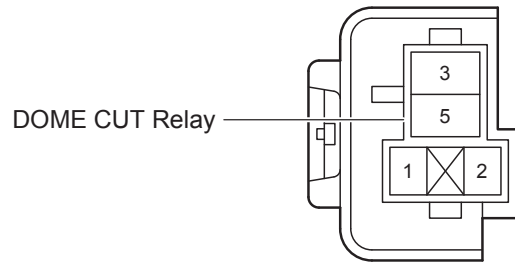

[R/B No. 5 Inner Circuit]

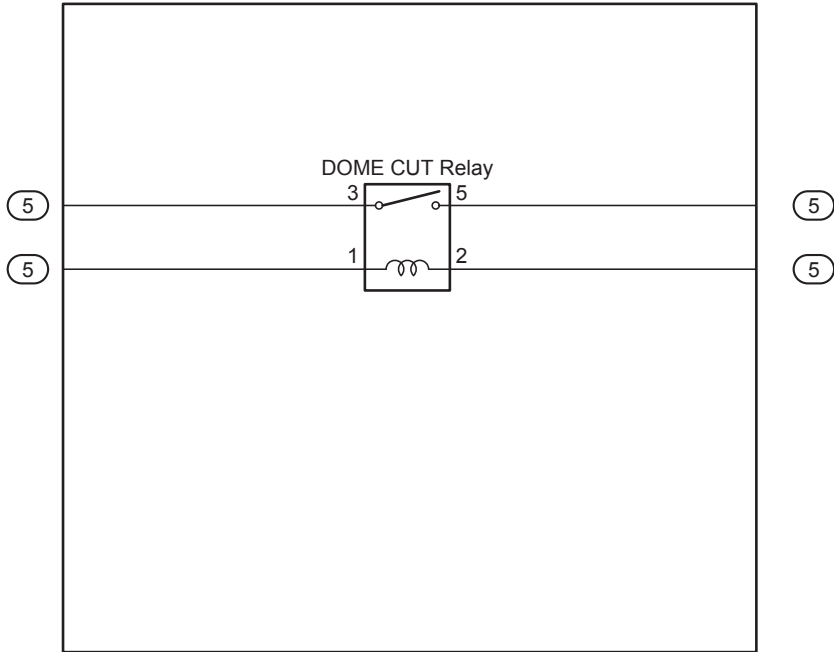

[Seat]

